



EMITTANCE SCANNER

ES-100.10K/CTRL-ES.11A

A system for measuring current distribution and particle trajectory in low-energy ion beams, designed for large-diameter beams and high thermal loads



Probe (ES-100.10K)

- **Characterizes emittance in low-energy charged particle beams (<1 MeV)** across large apertures and long scan ranges
- **Heavy-duty, water-cooled head supports up to 10 kW beam power with power densities up to 100 W/cm²,** enabling measurements of high-current, high-heat-load beams
- **Integrated analysis software computes phase-space ellipses by RMS or** by selectable beam fraction and generates publication-ready plots
- **Delivers essential phase-space data** for ion-optical modelling and validation of beamline transport designs
- **TRIUMF-licensed technology²**

The **Emittance Scanner** is an Allison-type instrument that mechanically scans across the beam, stopping at defined positions (y) to perform electric trajectory sweeps that record the current from particles at different angles (y'). The system is delivered fully integrated, with a probe for beamline installation and a remote control unit containing the power supplies, motion controller, picoammeter, and data-logging electronics. Configurations with a second probe for perpendicular phase-space measurements are also available. The instrument is suitable for ion sources, cyclotrons, and both **continuous** and **pulsed** low-energy beam applications.

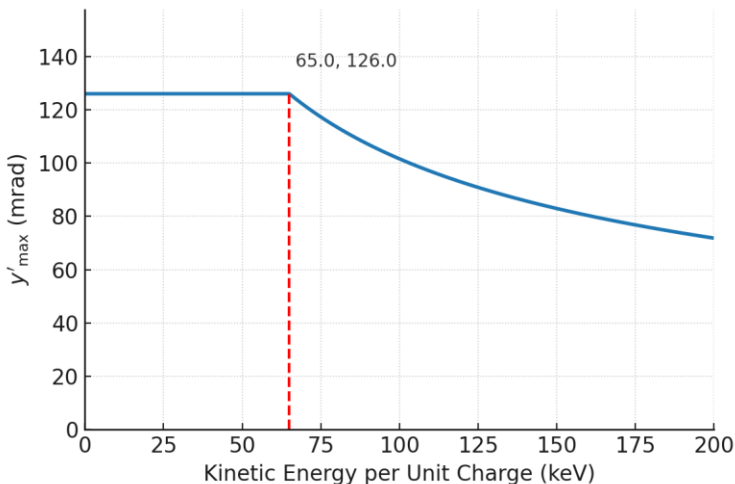

Maximum scan angle as a function of kinetic energy per unit charge³.

SPECIFICATION: EMITTANCE PROBE

Maximum Travel	250 mm
Distance, Slit to Flange	95 mm to 345 mm
Flange	Custom, Rectangular, O-Ring
Y Resolution	100 μ m
Y Step, Minimum	1 μ m
Y' Max	± 126 mRad (for KE <65 keV)
Y' Resolution	1.2mRad
Y' Step, Minimum	16 bit resolution over +/- Y' Max
Sweep Voltage	± 1250 V
Slit Width	100 μ m nominal Factory configurable 25 to 250 μ m
Slit Length	104 mm
Beam ϕ_{max}	100 mm
Bias Voltage	-100 V
Electrode Gap	6.0 mm
Electrode Length	76 mm
Mass	36 kg
Cooling Water	15 LPM @ 200kPa (30 PSI) 18 LPM @ 270 kPa (39 PSI) 23 LPM @ 450 kPa (65 PSI)
Max Beam Power ³	10 kW
Max Beam Intensity ³	100 W/cm ² @ 10 kW Beam Power
Cooling Plate	Molybdenum/Copper
Slits	Molybdenum

SPECIFICATION ¹ : CONTROLLER (CTRL-ES-11.A)	
Platform	Embedded Linux
Compatibility	Windows/Linux/EPICS
Typical Scan Time	<1 minute for a 30-step y by 30-step y' scan
Current Measurement Range	2 nA to 2 mA (full scale), 5 pA typical noise floor
Power	100-240 VAC, 50/60 Hz, single phase, 400 W
Data Plots and Analysis	2D & 3D phase-space intensity distributions, computed emittance, RMS ellipses, Twiss parameters
File Export	.csv
Dimensions (W x D x H)	3U rackmount chassis 19 x 22 x 5.5 (inches)
Mass	12 kg

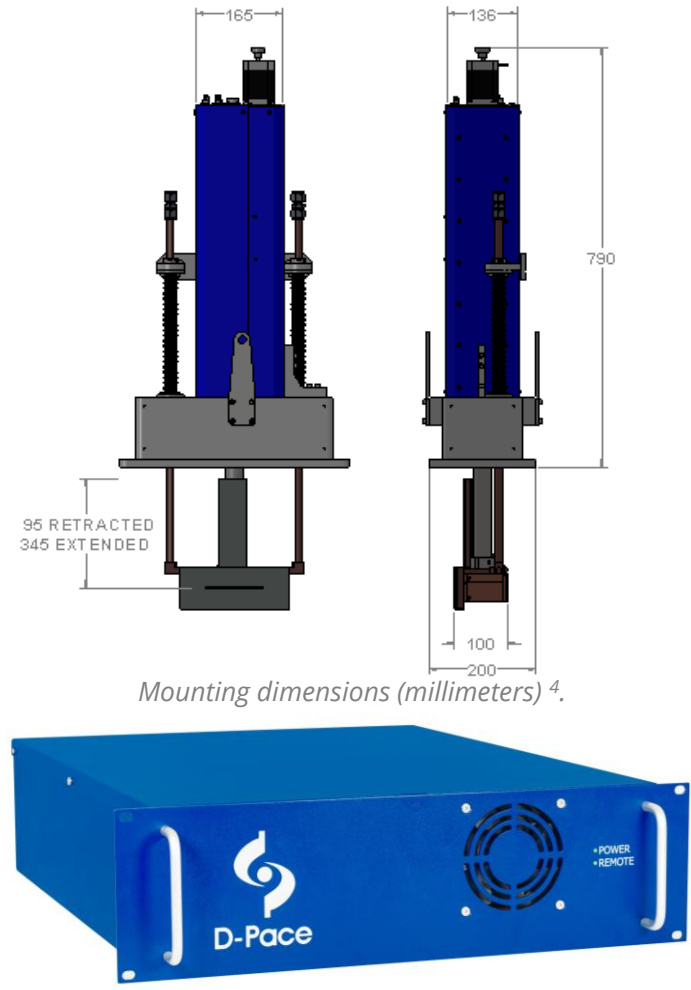

Mounting dimensions (millimeters) ⁴.

Controller (CTRL-ES-11.A)



Screenshot of the analysis software presenting results from a scan of a 1 mA, 300 keV H- beam.

1. Licenced from TRIUMF for exclusive world-wide distribution.
2. Vacuum boxes available. Contact D-Pace.
3. Higher power density can be achieved with lower total beam power. Contact D-Pace with beam requirements.
4. D-Pace reserves the right to update specifications as part of its ongoing product improvement program.